

5.0 NUDURA PRODUCTS ON SITE STORAGE PACKAGING, UNIT ASSEMBLY, USAGE

NUDURA Corporation has one of the most complete lineups of products and accessories available today in the construction industry. NUDURA's Integrated Building Technology is unique in the respect that the form lineup includes assembled forms along with unassembled panels, which allows for greater flexibility to achieve complex designs. Along with these forms, NUDURA Corporation carries the most extensive lineup of accessory products that enhance the most advanced product in the market

5.1 PRODUCT PACKAGING

The manner by which NUDURA material arrives on the building site and what preparations may be necessary with the materials before installation begins is the basic purpose of this section.

For the vast majority of NUDURA's Integrated Building Technology Product Line-up, the forms (or ancillary products) are either wrapped in plastic, or put into boxes. Below is a chart of NUDURA's core products and how they are packaged for when they arrive on site;

| Product Name | Wrapped in Plastic | Box | Taped |
|-------------------------------|--------------------|-----|-------|
| Standards | ✓ | | |
| 90° Corners | ✓ | | ✓ |
| 45° Corners | | | ✓ |
| T Forms | ✓ | | ✓ |
| Brick Ledge Forms | ✓ | | |
| Taper Top | ✓ | | |
| Brick Ledge Extensions | | ✓ | |
| Radius Wall | ✓ | | |
| Optimizer | ✓ | ✓ | |
| Height Adjuster | ✓ | | |
| End Caps | | ✓ | |
| Unassembled Panels | ✓ | | |
| Insert Webs | | ✓ | |
| Floor Technology | ✓ | | |
| Ceiling Technology | ✓ | | |

OPENING & SET-UP OF NUDURA PRE- ASSEMBLED VERSUS SITE ASSEMBLED FORM COMPONENTS

As discussed in Chapter 2, NUDURA products come in either fully assembled forms or component assembled products that the installer manually assembles on site. Chances are that 90 to 95 percent of any job you execute will be with NUDURA's fully assembled form components. Specialty top course forms – radius wall forms or T forms – will usually be the only exception to this general rule.

NUDURA's form technology (and the wide scope of its installation flexibility) is based on the deployment of two patented hinge and web assembly types that are both incorporated into the form system:

1. Integrally molded steel hinge pin webs that form part of both the cross tie and the fastening strip component of the web
2. Separate molded HD Polypropylene Insert webs which slide fit into HD Polystyrene Web fastening strips that are integrally molded into the insulation components of either a fully assembled form OR separate molded insulation panels, or form profiles which are either partially or fully assembled into a form or remain completely unassembled allowing the form to be shipped as a flat panel set that will be assembled manually on site.



FIGURE 5.01

The key difference from other component assembled form systems on the market is that for NUDURA's primary market Standards and Corner forms, there is no need to execute any pre-assembly. The opening of the forms as described below can easily occur as part of the assembly of the form into the wall.

STANDARD FORMS, 6" AND 8" (152 mm AND 203 mm) BRICK LEDGE AND TAPERED TOP FORMS

Standard Forms for NUDURA's 4" (101 mm) core through to 10" (254 mm) Core Forms, as well as 6" (152 mm) core, preassembled Brick Ledge and Tapered Top Forms come factory assembled with NUDURA's patented integrally molded steel hinge pin web fastening strip system. The 12" (305 mm) Standard Forms, as well as 8" (203 mm) core Brick Ledge and Tapered-Top Forms, also arrive at the site factory assembled, but are constructed with standard panels using NUDURA's insert webs and NUDURA® Panels with polystyrene web fastening strips.

The forms arrive shrink-wrapped in bundles of 3 forms per bundle – each bundle weighing approx 45 lbs (20.4 kg). When folded flat, the form is basically a fully collapsed parallelogram with one form panel slid forward of the other during shipping and storage. NOTE: depending upon your area, the Tapered Top and Brick Ledge Forms are available as either 4' (1.22 m) or 8' (2.44 m) length forms. Check with your distributor to know which form type is available in your area and be sure your quantity of forms reflects the unit length available for your region.



FIGURE 5.02

Once the plastic shrink wrap is slit and peeled off, opening the form is easy. The user simply places the form so that the lower of the 2 panels is the one closest to their body. Placing this panel against the abdominal muscles (See Figure 5.03), the user firmly grabs the upper panel and pulls it towards themselves until the hinge webs are opened to a position fully perpendicular to the panels.



FIGURE 5.03

CORNER FORMS

Both 90° and 45° corner forms for all core thicknesses are also shipped folded for maximum efficiency, but, as noted in Chapter 4, are always shrink wrapped and shipped nested in pairs, stacked 6 forms to a bundle, end to end, to resemble the length and bulk of the shrink wrapped standard bundles. Again, as noted in Chapter 4, these forms are stored interlocking, facing up and down, to protect the nested corner components from damage due to vertical stacking pressure. Except for 12" (305 mm) cavity forms, all corner forms are assembled with a combination of hinge pin and insert webs, the hinge pin webs always comprising of the 2 outer most webs on the long end of the form, and the last web before the corner being a pre-assembled insert web/polystyrene fastening strip combination. This maximizes the forms' strength at the corner condition.

Like the 12" (305mm) Standard, the 12" (305 mm) Corner Form contains no hinge pin webs so all of the webs are insert type with the short side of the form being a free unassembled insert web that is placed once the form is folded out to its deployed position.

Once unwrapped, the only difference from the Standard Forms is to unfold the nested interior and exterior panels, pull out the stowed, unassembled insert web (included with each form), and insert it into the web capture lugs of the polystyrene fastening strips located on the short end of the corner. This completes the corner assembly ready for placement.

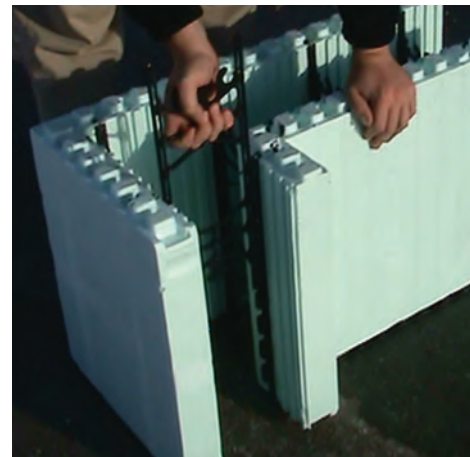

FIGURE 5.04

SPECIALTY FORMS, T FORMS AND FACTORY CUT RADIUS FORMS

All above noted forms arrive shrink-wrapped as separate panel components molded with web fastening strips and (depending on product) may or may not require separate insert webs to be ordered in box quantities as part of the order. Double check your product catalogue or with your NUDURA distributor directly to be sure. Specialty forms include ANY of the following:

- 4", 10" and 12" (102 mm, 254 mm, and 305 mm) Taper Topped Forms
- 4", 10" and 12" (102 mm, 254 mm, and 305 mm) Brick Ledge Forms
- Double Sided Tapered Top Forms any core thickness
- Double Sided Brick Ledge Forms any core thickness
- T Form Units and Core Thickness combination or common core size
- Factory Cut Radius Forms

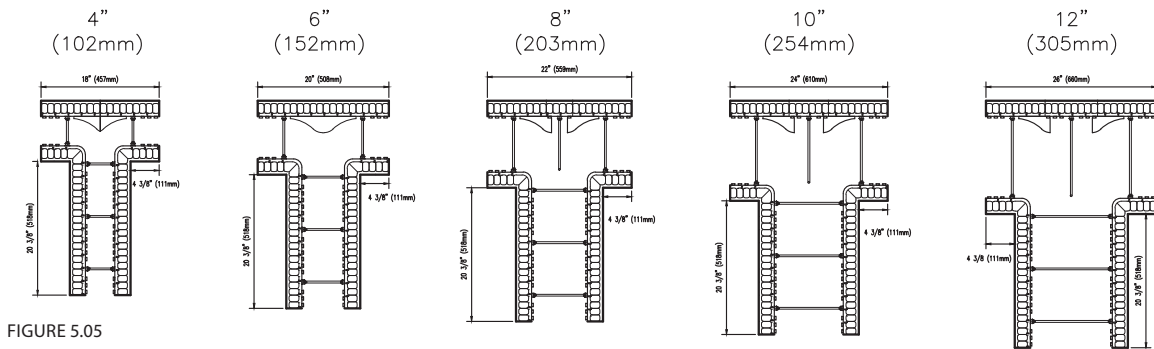

FIGURE 5.05

For Double Sided Tapered Top Forms and Double Sided Brick Ledge Forms, the products will arrive to site shipped with separate standard panels. This is because the same molds that are used for forming standard assembled tapered top and one side brick ledge forms are used for these products as well with fastening strips installed instead of fully assembled hinge pin webs. Be sure you accommodate for these nuances on your product counts and quantities.

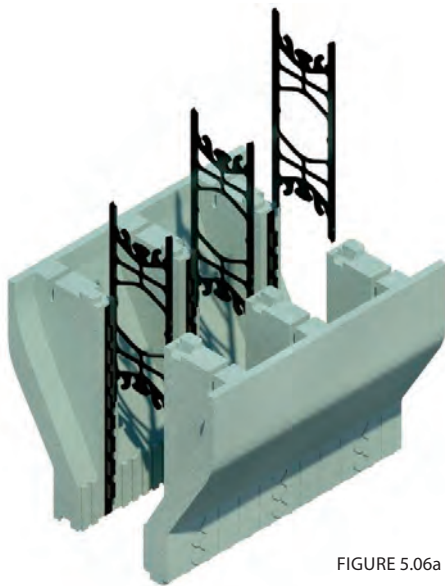

FIGURE 5.06a



FIGURE 5.06b

With T Forms, the main wall exterior panel is also molded from a common sized mold that is intended to be adapted for ALL core thicknesses of T Form. For this reason, remember that the main wall panel will require component assembly and form support on site for 4", 10" and 12" (102 mm, 254 mm, and 305 mm) core forms.

Additionally note that factory cut radii components when shipped will consist of full length 8' panels and multiple custom cut interior panel segments each less than 8" in length to suit the radii noted. Always keep these components separate and designated to their intended radius if multiple radius walls are being installed on site. Prep work for the main exterior panel may be required which is covered in the Bulletin pertaining to Radius Walls found in Appendix F.

5.2 NUDURA ALIGNMENT SYSTEM

SITE ARRIVAL AND PACKAGING

NUDURA's Alignment System is available with 8' (2.44 m), 10' (3.05 m), and 12' (3.66 m) box channels. All components fit neatly in a steel crate that holds 20 complete sets of bracing. Should replacement parts need to be ordered the chart below will give the contractor/installer the part name and number for the alignment system components.

| Part Name | Part Number |
|---|----------------|
| Turnbuckle | tbukl |
| Base Plate | bplate |
| Catwalk Bracket | catbra |
| Guard Rail Post | grail |
| 3/8" x 2 1/2" Lock Pin (9.5mm x 63.5mm) | lockpin |
| 5/8" x 3" Bolt & locking Nut (16mm x 76mm) | boltnut |
| 1/2" (13mm) Gravity Pin | g-pins |
| 8' (2.438m) Box Channel | cha8 |
| 10' (3.048m) Box Channel | cha10 |
| 12' (3.658m) Box Channel | cha12 |



FIGURE 5.07

5.3 NUDURA FORM-LOCK



FIGURE 5.08

SITE ARRIVAL AND PACKAGING

The form lock NUDURA uses within the form cavities is specifically manufactured to the specifications of the forms. NUDURA FORM-LOCK comes in widths that fit within the wall cavities of the 6" (152 mm), 8" (203 mm), 10" (254 mm), and finally the 12" (305 mm) form units. All FORM-LOCK sizes are available in 10' (3.05 m) and are bundled in 100' (30.5m) packages.

USES

NUDURA FORM-LOCK can be used in multiple areas of the project and its primary function within the NUDURA® Integrated Building Technology is to ensure the walls maintain straightness. NUDURA recommends that FORM-LOCK be used in the second course of forms and in every 3rd or 4th course after that. Additional uses are in vertical stack joints and window sills to ensure these areas maintain straightness until the concrete has cured.

5.4 VERTICAL JOINT CLIPS

FIGURE 5.09



SITE ARRIVAL AND PACKAGING

The vertical joint clips are pre-bent steel wire that enables locking at the vertical joints of the forms and are packaged with 200 clips per box. The clips are 8 5/8" (219 mm) in length and clip onto the web where it connects to the EPS.

USES

The vertical joint clips are to be used for connecting corner forms to the standard form units. The purpose of the vertical joint clip is to replace the use of tape or tie wire and to provide a solid secure connection with minimal amount of labor. This helps in ensuring no additional movement occurs during concrete placement with the forms. Typically the installer will use 8 vertical joint clips per corner to standard connection, and 4 clips for the standard to standard connection on the first course of forms. All subsequent courses will only require 4 in the corner to standard connection and 2 in the standard to standard connection. Proper installation of this product is discussed in chapter 6 of this manual.

5.5 V-CLIPS

SITE ARRIVAL AND PACKAGING

Like the vertical joint clip, the V-Clip is a pre-bent galvanized steel wire accessory that is useful in multiple applications but is more suited to specific attachment requirements in commercial construction, or where concrete floor decks are being used in conjunction with NUDURA®. The clips come in boxes of 250. They measure 8" (203 mm) wide x 10" (254 mm) long and feature prongs at each end of the V-clip about 1 1/2" (38 mm) in length that are inserted into the web connection lugs of NUDURA®'s standard 8' (2.4 m) panels.

USES

The V-Clip Accessory's primary function is to help stay the free end of NUDURA 8' (2.4 m) standard panels in position wherever a concrete precast floor connection is anticipated. Once the precast panel is in place, the V-Clips are installed at 16" (406 mm) centers down the length of wall by drilling holes in the hollow core slab approx. 10" (254 mm) away from the inside face of the NUDURA panel and longitudinally down the axis of the wall midway of every other web space. The prongs on the clips are inserted into the panel connection lugs and then secured at their bend apex into the drilled holes using a tie wire insert and nail or screw sized to suit the hole. This technique can be adapted to suit any condition where the top condition of a NUDURA panel must be stayed in position horizontally for subsequent construction of a floor pour.

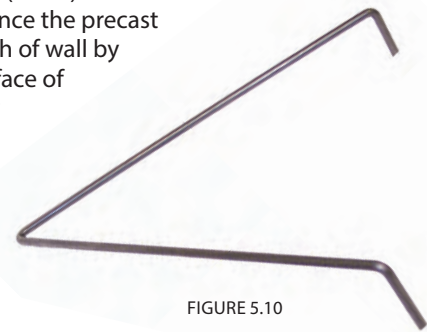

FIGURE 5.10

5.6 FORM TRANSITION BRACKET

SITE ARRIVAL AND PACKAGING

The Form Transition Bracket is a stamped galvanized metal plate accessory that is useful in supporting the free panel of any NUDURA form of a differing core thickness from the form thickness installed below it, during wall construction and concrete placement. The bracket measures about 1 1/2" (38 mm) in width x 8" (203 mm) in length and features stamped cleats that are pre-designed to clip over 15M or No. 5 diameter reinforcing steel. This accessory comes in boxes of 100.

USES

The bracket can be used to support the free panel (either inside or outside) of a NUDURA® form whenever a transition from a greater to lesser core thickness of form is anticipated (i.e. moving from a 10 inch (254 mm) tapered top form to a standard 6 inch (152 mm) core form to create a brick ledge condition). The brackets are typically installed every 2nd or third web by simply clipping the stamped lugs onto the closest supporting reinforcing steel bar, installed in the top of the wider core form below and aligning the bracket to the web and face surface of the form, then screwing it into place once the form above has been leveled to its required height.



FIGURE 5.11

5.7 NUDURA SPRAY FOAM, FOAM GUNS AND GUN CLEANER SOLUTION

SITE ARRIVAL AND PACKAGING

NUDURA® Spray Foam is a polyurethane based low expansion foam that is shipped in boxes of 12 – 24oz (680g) cans per box.

The foam guns are shipped by box – 1 pc/box and gun cleaner arrives also in boxes of 12 cans per box.

USES

NUDURA® Spray foam, guns and gun cleaner products are indispensable on a NUDURA Site, enabling the installer to tackle everything from quick tack anchorage of the forms to the footings or slab at 2nd course leveling, additional form support or adhesion during assembly of cut components such as panels or radius wall components, filling in cut imperfections of EPS panel joints, filling cut gaps around insert sleeves, completing airtight window opening seals and so on.



FIGURE 5.13



FIGURE 5.12

5.8 MASONRY TIES

SITE ARRIVAL AND PACKAGING

The NUDURA® Cast In Place (C.I.P) masonry tie system is available in galvanized or stainless steel and is shipped in 2 boxes; 100 wall ties and 100 pintles.

The NUDURA® Surface Mount masonry tie system is available in galvanized steel and ships in one box of 100 pieces. Pintles are available separately in one box of 100 pieces.

USES

The CIP Masonry Tie was specially designed to a wide loop profile with sharp pointed ends to allow cast tie portion of the accessory to be pressed through the exterior EPS foam panel under normal hand pressure. This eliminates the need to cut the foam for installation into the wall, which can compromise the strength of the form during the concrete pour (figure 5.14).

The Surface Mount Masonry Tie (galvanized) was designed to be fastened with 2 NUDURA Hex head Screws anywhere on the NUDURA fastening strip. This tie will accept NUDURA Pintels and other smaller dimension pintels. The surface mount masonry tie is manufactured with stops that penetrate the foam but prevent the tie from being over tightened and compressing the foam (figure 5.15).



FIGURE 5.14



FIGURE 5.15